

1" PROFESSIONAL AIR IMPACT WRENCH

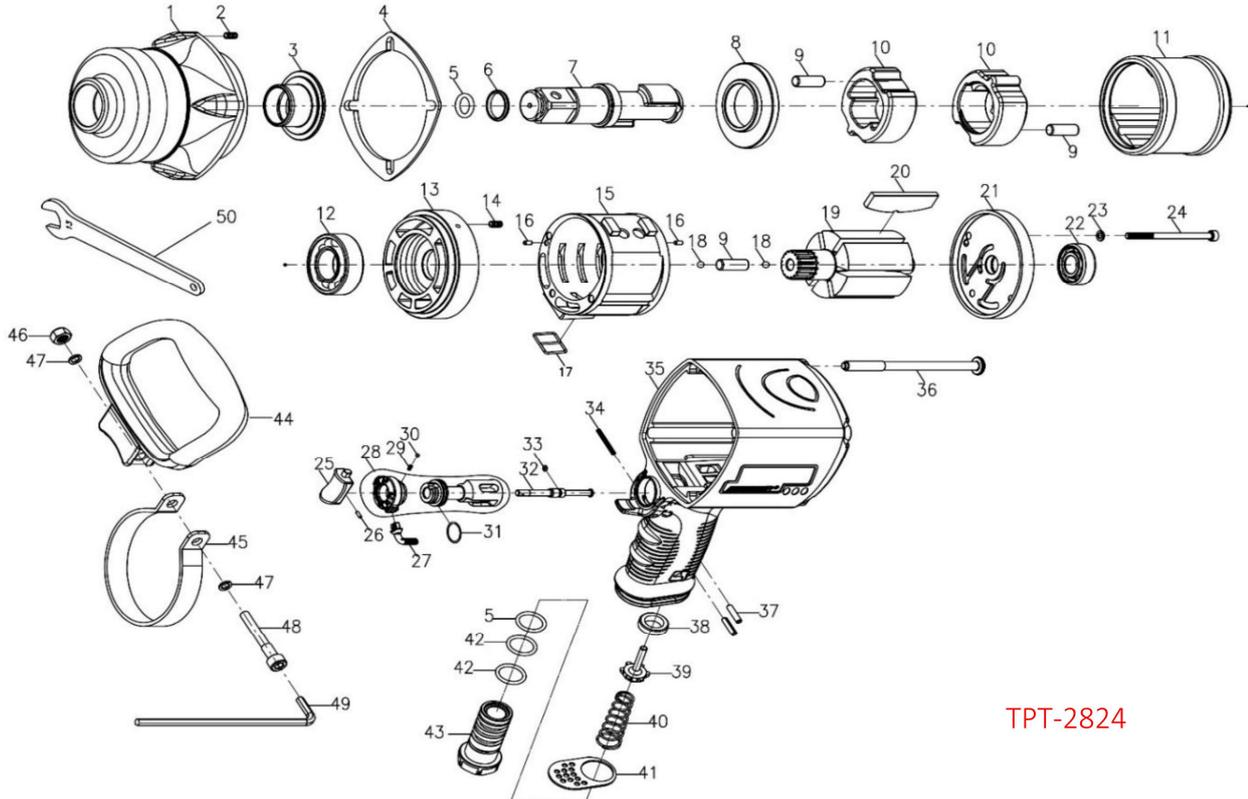

TPT-2824

Index No.	Part No.	Description	Q'ty	Index No.	Part No.	Description	Q'ty
1	2824-002	Hammer Case	1	27	243Q-035B	Tab	1
2	00-4303	Helicoil(M8x1.5D)	4	28	2824-034B	F/R Lever	1
3	2824-010	Anvil Bushing	1	28	2824-021	R/F Valve	1
4	2824-022	Front Gasket	1	29	305Y-027	Spring	1
5	00-4124	O-Ring(P18)	2	30	00-3816	Steel Ball(ψ2.5)	1
6	310-038	Anvil Collar	1	31	00-41145	O-Ring(ψ18×ψ1.5)	1
7	2824-011C8	Anvil	1	32	2824-029	Trigger pin	1
	2824-011D8	7"Anvil	1	33	00-4196	O-Ring(ψ5×ψ1)	1
	2824-011E8	3"Anvil	1	34	00-3358	Spring Pin(ψ3×28L)	1
8	2824-019B	Hammer Cage Cover	1	35	2824-001	Motor Housing	1
9	2824-016	Hammer Pin	3	36	2824-028	Screw	4
10	2824-017B	Hammer	2	37	00-3323	Spring Pin(ψ4×18L)	2
11	2824-012B	Hammer Cage	1	38	314-027-B	Bushing	1
12	00-2301	Ball Bearing(6205Z)	1	39	314-026-B	Valve Stem	1
13	2824-005	Front End Plate	1	40	318F-036-B	Spring	1
14	00-4302	Helicoil(M5x1.5D)	3	41	2824-035	Exhaust Deflector	1
15	2824-006	Cylinder	1	42	00-4133	O-Ring(P20)	2
16	00-3460	Pin(ψ4×8L)	2	43	2824-025A	Air Inlet (1/2"PF)	1
17	2824-030	Square Ring	1		2824-025B	Air Inlet (1/2"PT)	
18	00-3823	Steel Ball(ψ5)	2		2824-025C	Air Inlet (1/2"NPT)	
19	2824-007	Rotor	1	44	2824-026B	D-Type Handle	1
20	2824-008	Rotor Blade	6	45	2824-024B	Handle Clamper	1
21	2824-009	Rear End Plate	1	46	00-2001	Lock Nut	1
22	00-2304A	Ball Bearing(6202)	1	47	00-1808	Spring Washer (M8)	6
23	00-1802	Spring Washer(M5)	3	48	00-0167	Cap Screw (M8x60L)	1
24	00-0166	Cap Screw(M5x75L)	3	49	00-3909	6 mm Hex. Wrench	1
25	2824-023	Trigger	1	50	531-030	Spanner	1
26	00-3325	Spring Pin(ψ2×6L)	1				