



KITS



PUMPS



METERS



METERED NOZZLES



NOZZLES



WASTE OIL EQUIPMENTS

K400

FEATURES

- READY TO USE
- EASY TO CALIBRATE
- DOUBLE TOTALIZER
- ELECTRONIC RESET FUNCTION
- HIGH ACCURACY
- LOW BATTERY CONSUMPTION
- RUBBER PROTECTION
- ADJUSTABLE UNIT OF MEASUREMENT

The PIUSI K400 is an electric oval gear meter suitable for monitoring the delivery of oils with a wide range of viscosity. The meter is equipped with a digital display and it is also available in pulser version.

PERFORMANCE

UP TO 1-30 L/MIN	MAX 70BAR
FLOW RATE	OPERATING PRESSURE
± 0,5%	0,3%
ACCURACY	REPEATABILITY



K400



K400 PULSER



PACKAGING

CODE	WEIGHT		PACKAGING			
	KG	LBS	MM	INCH	PCS/PALLET	PCS/BOX
METER						
FOO484000	0,5	1,1	298X198X113	11,7X7,8X4,4		12
PULSER						
FOO440200	0,5	1,1	300X160X110	11,8X6,3X4,3		8



FILTRATION



FLUID MONITORING



TANK MONITORING



HOSE REELS



ACCESSORIES



MERCHANDISE



AIR



ANTIFREEZE



AdBlue®



BIODIESEL



DIESEL



FOOD



GASOLINE



GREASE



KEROSENE



OIL



WATER



WINDSCREEN

CHART



DIMENSIONS

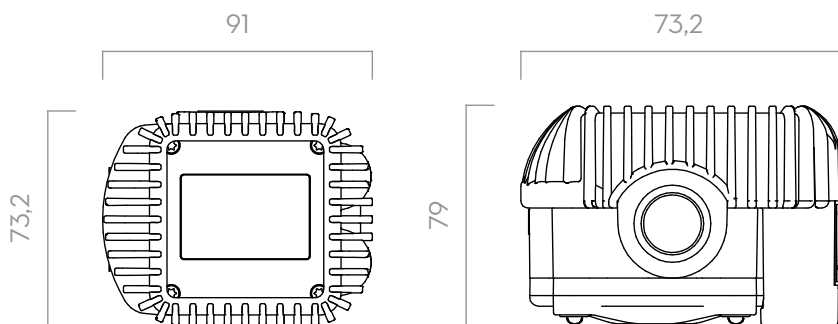

Dimensions expressed in millimeters

IN THE BOX

- K400 METER
- INSTRUCTION MANUAL

DETAILS



MATERIALS

- BODY: ALLUMINIUM
- GEARS: TECHNOPOLYMER

TECHNICAL DATA

CODE	DESCRIPTION	FLUIDS TYPE	FLOW RATE		WORKING PRESSURE		BATTERIES INCLUDED AAA NO.2 2 X 1.5 V	INLET	OUTLET
			L/MIN	GPM	BAR	PSI			
METER FOO484000	K400 METER .7" BSP		1-30	0,26 - 7,8	70	994	YES	1/2" BSP	1/2" BSP
PULSER FOO440200	K400 PULSER .7" BSP		1-30	0,26 - 7,8	70	994	NO	1/2" BSP	1/2" BSP

UPON REQUEST AVAILABLE IN NPTF VERSION AND DISPLAY IN GALLON/QUARTER OR PINT

K400